

c面: 外表面。

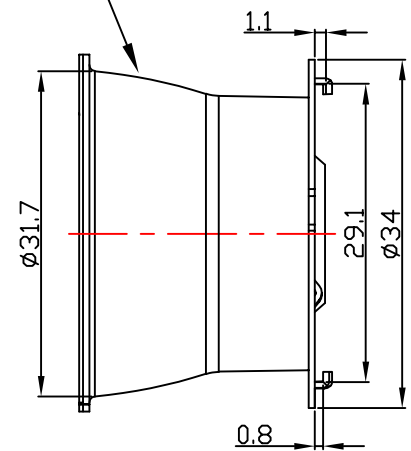

Light Source	LUMILEDS 1202HD
PlasticHolder	92.70.410.00
Metal Adapter	
Design Angle	$28^\circ \pm 3^\circ$
Measured Angle	$27.8^\circ$
Efficiency	

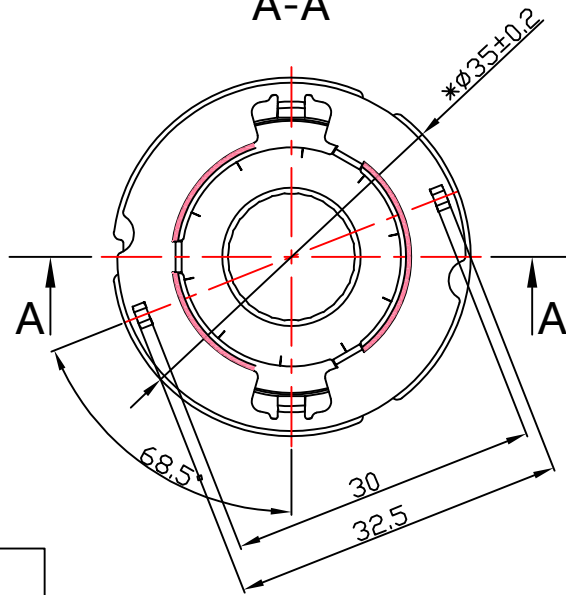
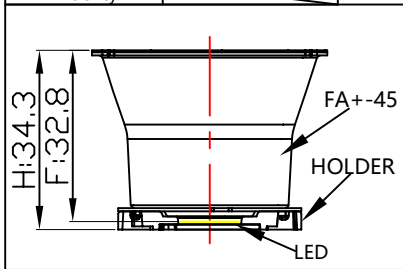

Technical requirements:

- 1.\*\*\*KEY CONTROL DIMENSION.
- 2.Tolerances not noted are in accordance with the tolerance table.
- 3.unmarked rounded corners Press for 3D.
- 4.Surface without imprint, black spots, cracks, wrinkles and other poor.

PRODUCT BOM

NO.	PRODUCT NAME	P/N:	QUANTITY	MATERIAL/FINISH
①	1-1200-M卡扣	97.77.072.00	1	T=0.6mm SUS301
②	1-1202-A	94.01.1202.000	1	T=0.6mm 1070AL/Anodizing
③	1-1201-A	94.01.1201.000	1	T=0.4mm High reflectivity aluminum(Mirror surface)

标记	处数	更改内容	签名	更改日期
MARK	NO.OF MODIF	MODIFICATIONS	SIGNED BY	MODIF. DATE
设计	制图	比例	1:1	
DESIGNER	DRAWN BY	SCALE		
工艺	审核	视角		
TECHNICAN	CHECKED BY	1st ANGLE PROJECTION		
批准	日期	18-02-2022	页数	SHEET 1 OF 1
APPROVED BY	DATE(DD-MM-YYYY)		PAGE	

DIMENSION TOLERANCE TABLE (UNLESS OTHERWISE STATED)						
> 0-5	> 5-30	> 30-90	> 90-150	> 150-250	> 250-400	> 400-700
±0.15	±0.2	±0.4	±0.5	±0.8	±1.5	±2
PUNCH TOLERANCE TABLE (UNLESS OTHERWISE STATED) (ANGLE)						
> 0-10	> 10-50	> 50-120	> 120-250	> 250-360		
±1°	±0.5°	±0.3°	±0.2°	±0.166°		
产品图 PRODUCT DRAWING						
						单位 UNIT mm

<b>Nata</b> <sup>®</sup>		版本 VERSIONS K
产品编码 PRODUCT CODE	91.01.1374.000	
产品名称 PRODUCT NAME	1-1374-L	
客户代号 CUSTOMER ID	NT	
客户编号 CUSTOMER CODE	FA+-35-28D	